

VICOR CONFIDENTIAL
 THIS DOCUMENT AND THE DATA DISCLOSED HEREIN OR
 HEREWITH IS NOT TO BE REPRODUCED, USED OR
 DISCLOSED IN WHOLE OR IN PART TO ANYONE WITHOUT
 THE PERMISSION OF VICOR CORP.

REV.	DESCRIPTION	DATE	APPROVED
1	RELEASED PER E0230307	07/11/02	JMR
2	REVISED PER E080070	01/15/08	REJH
3	REVISED PER E091753	09/29/09	REJH
4	REVISED PER E092276	12/30/09	REJH
5	REVISED PER E120065	01/20/12	KUK

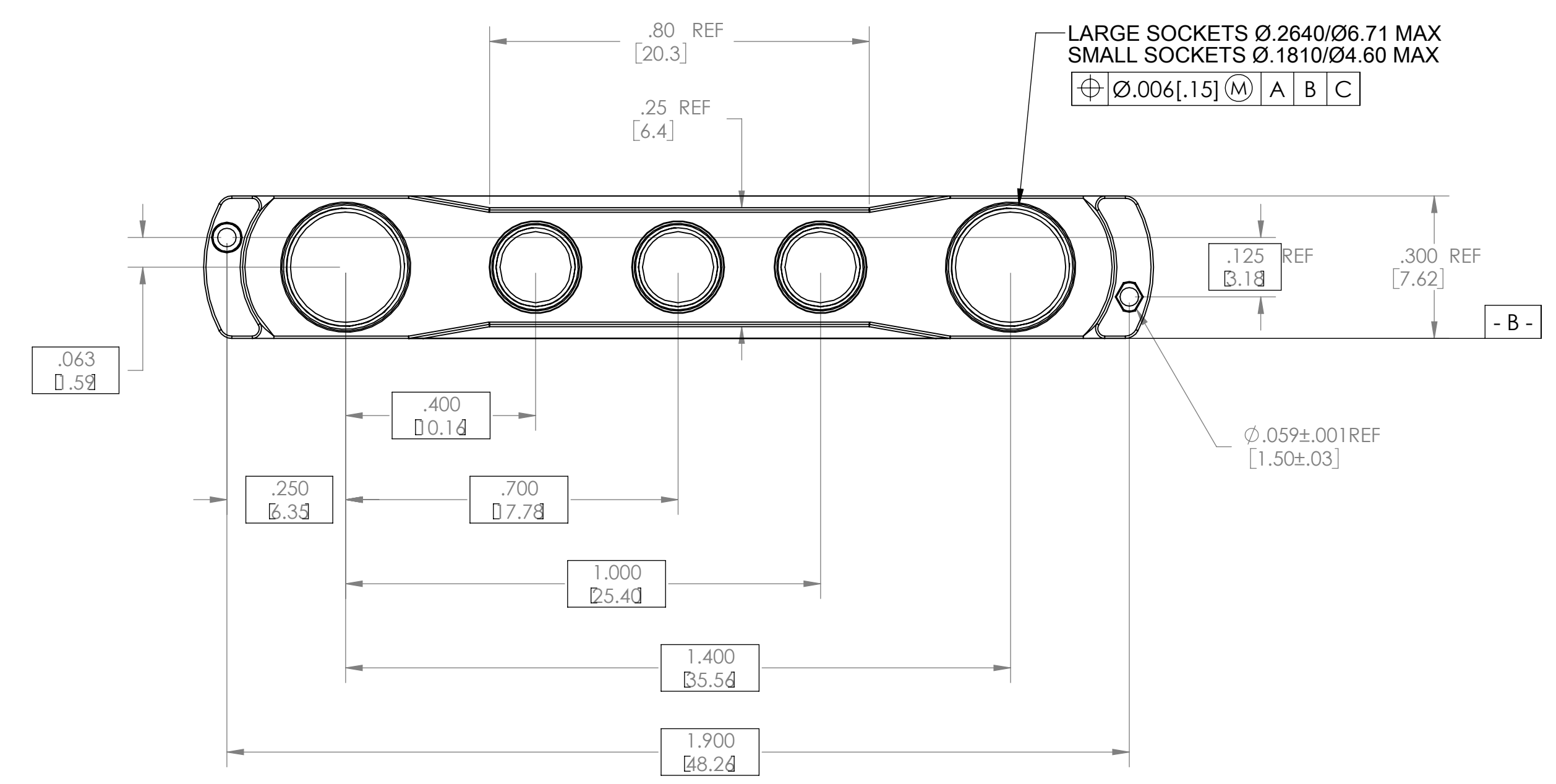
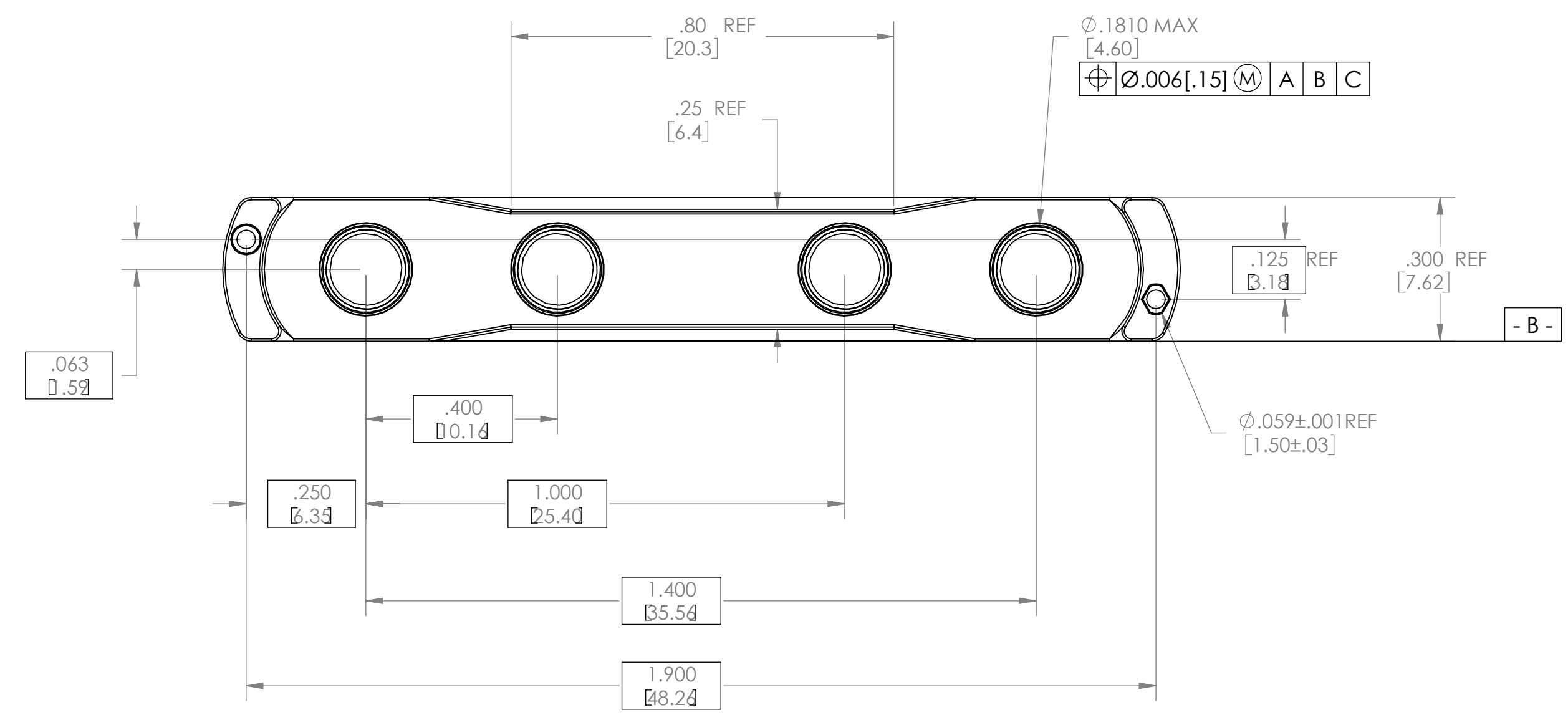
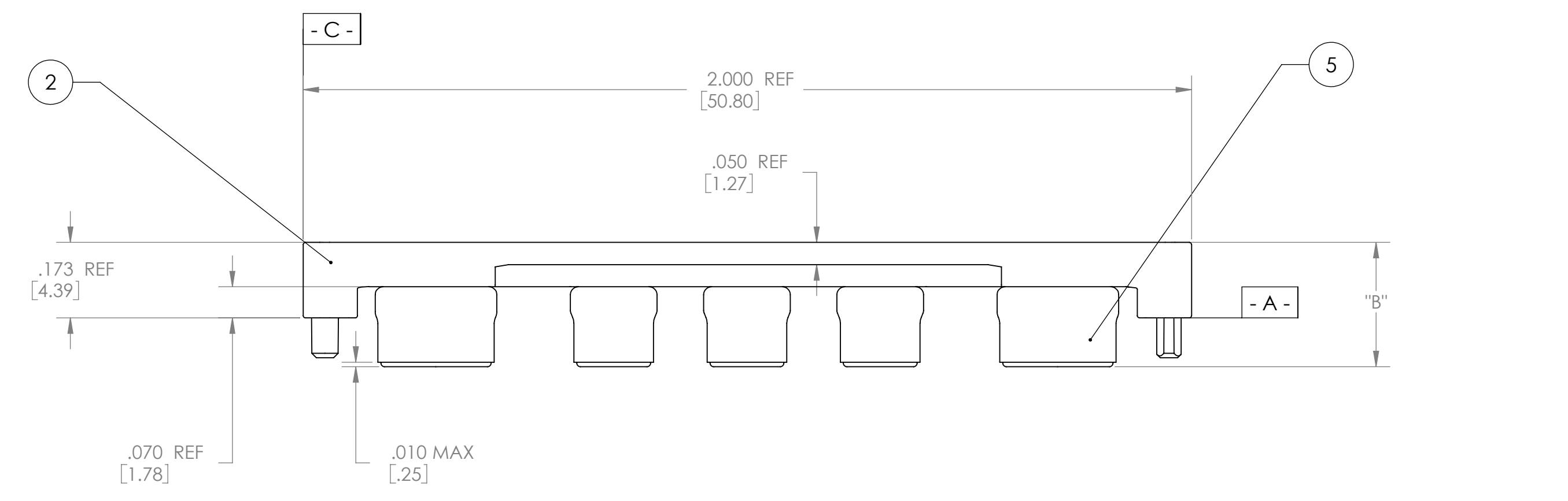
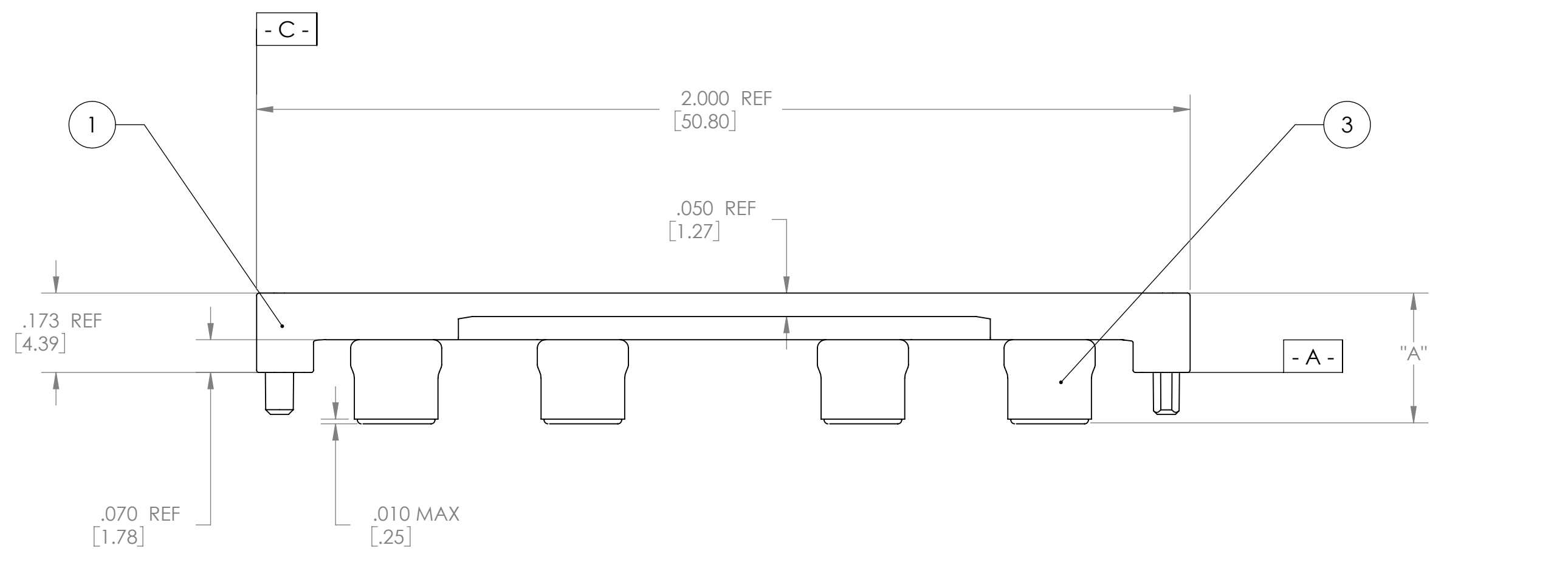
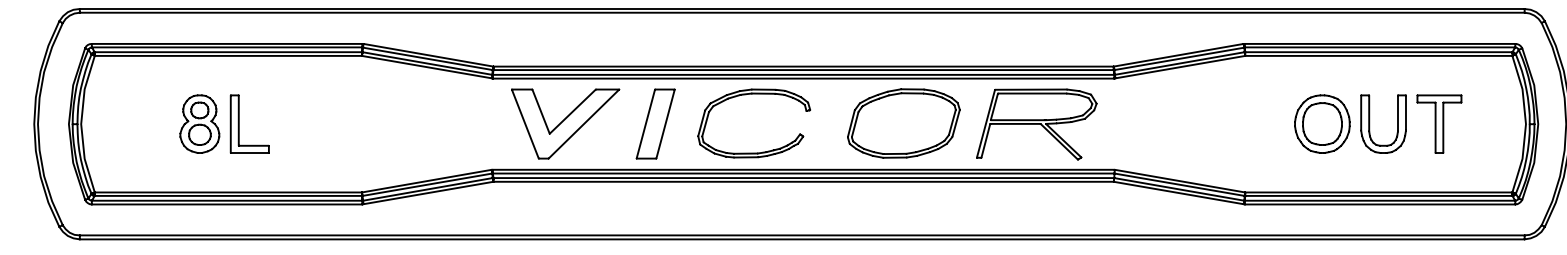
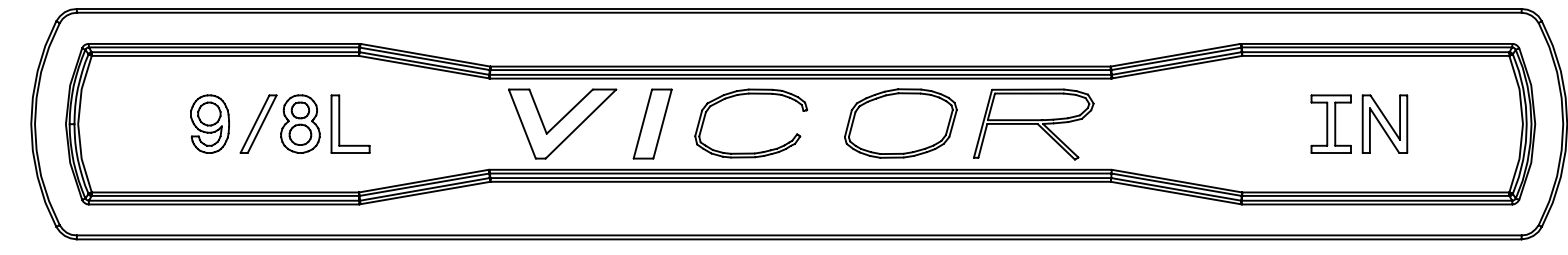

DASH NO.	SOCKET BODY LENGTH INCH./MM	DIA "A" INCH./MM	DIA "B" INCH./MM	INPUT	OUTPUT	KIT #
-01	.100/2.54	.280/7.11	.280/7.11	18378	18390	18368
-02	.135/3.43	.315/8.00	.315/8.00	18379	18391	18369
-03	.160/4.06	.340/8.64	.340/8.64	21539	21544	21511

- NOTE:
 1. MATERIALS: INMATES: PPS RYTON 7
 SOCKETS: BE-CU #25, Au PLATED.
 2. FULLY SEAT SOCKET INTO INMATE HEADER.
 3. ROHS COMPLIANT PER CST-0001 LATEST REVISION.

DRAWN BY: LAP NGUYEN DATE: 6/99
 UNLESS OTHERWISE SPECIFIED DIMENSIONS ARE: INCH / (MM)
 TOLERANCES ARE: DECIMALS ANGLES
 XXX (X.X) = ±0.01 (0.25) °11
 XXXX (X.XX) = ±0.005 (0.127) °11
 THIRD ANGLE PROJECTION
 DO NOT SCALE DRAWING

SCALE: 4:1

SIZE: D CAGE CODE: 67131 DWG NO: 20030-XX REV: 5

SCALE: 4:1 SHEET 1 OF 1

VICOR

